

weim

SHREDDING + COMPRESSING

M SERIES

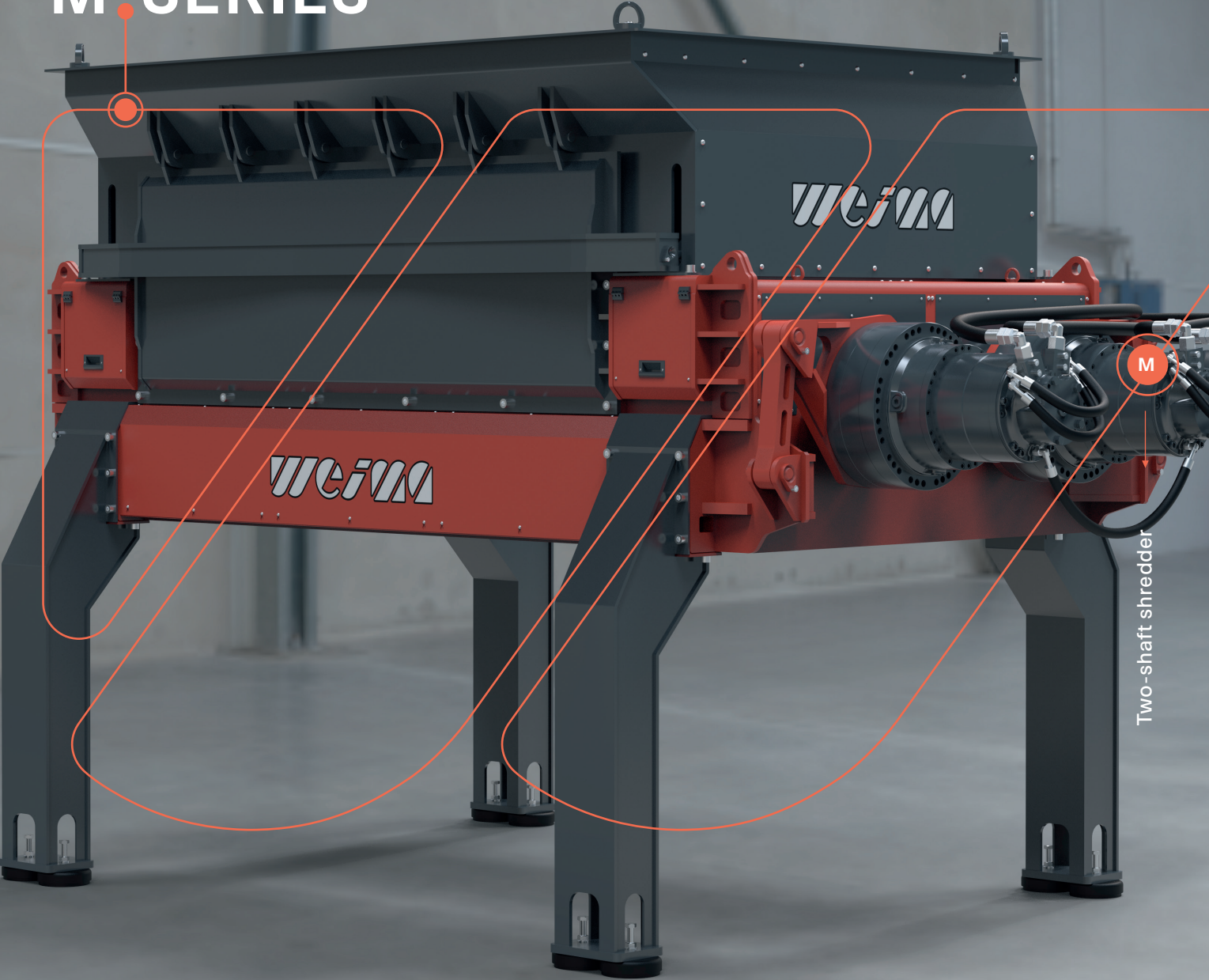

Two-shaft shredder

M

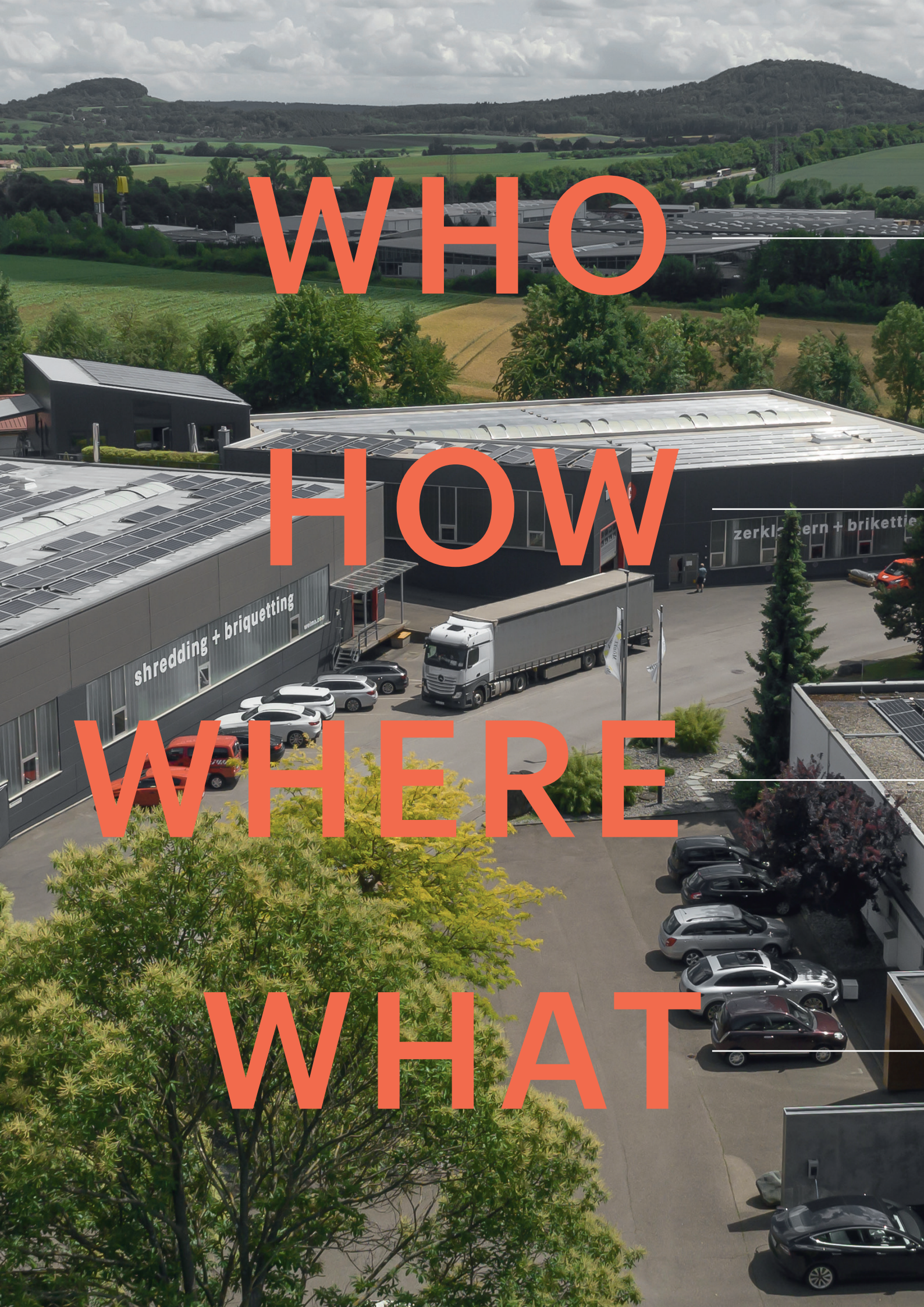

WHO

HOW

WHERE

WHAT

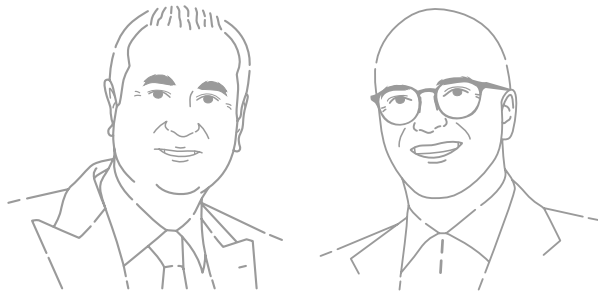

The family business.

The young entrepreneur and visionary Peter Rössler recognized the potential of waste recycling early on. In 1980, he founded Weinsberg Maschinenfabrik, or WEIMA for short. After the millennium, the generation change succeeded with Martin Friz, who has now been running the business since 2003.

>300           

      **65,000**

  **1,200**   

Global leader.

WEIMA produces more than 1,200 shredders, briquetting and drainage presses per year on a production area of approx. 65,000 sqm with more than 300 employees worldwide. Since its foundation, about 37,000 machines have been delivered. This is a world-wide top value.



Built in Baden-Württemberg, made for the world.

Thanks to the early international orientation, WEIMA is represented in all important markets. Sales and service locations are located in Europe, the USA, Poland, China and India.

1. Ilsfeld | HQ (DE)
2. Annaburg | Production (DE)
3. Abstatt | Production (DE)
4. Warschau | Service (PL)
5. Fort Mill | Sales & Service (US)
6. Yantai | Sales & Service (CN)
7. Gujarat | Service (IN)

From trash to treasure.

With WEIMA machines, there are (almost) no limits. For over 40 years, we have been shredding and compacting production waste from the fields of plastics, wood, paper, metal, packaging, waste and biomass.



TECHNICAL HIGHLIGHTS



Simple parameter adjustment

thanks to PLC control with large touch display

With the large touch display, you have all important data and settings in front of you at a glance. This makes it easy to flexibly adjust parameters such as the cutting shaft speed. With the Siemens PLC control system, not only the shredder but also the peripherals including conveyor belts, separation technology and secondary shredders can be controlled centrally via PROFINET and PROFIBUS systems. Material flows can thus be processed in an energy-efficient manner and maintenance can be optimized.

Constantly lubricated bearings

thanks to automatic central lubrication

The central lubrication system ensures that moving machine parts such as the cutting shaft bearings are always optimally lubricated at all times. This eliminates the need for manual lubrication.



Flexible adjustments of the cutting table

due to Easy Exchange System

The cutting table is easy to change thanks to the EES (Easy Exchange System). It can be lifted out of the machine frame together with the cutting shafts and easily replaced. Even with changing material flows, the shredder can thus be optimally adapted to customer requirements.

Easy integration into production lines

or as stand-alone solution

Optimally linked: WEIMA shredders have all common interfaces (PROFINET, PROFIBUS) to ensure fast integration into planned or already existing production lines. Thanks to the low loading edge, the shredder is ideally suited for direct filling via gripper, forklift or wheel loader, but also for conveyor belts. The elevated base frame offers plenty of space for all common conveyor belts. This means that large quantities of shredded material can be transported quickly and cleanly.



Part of the WEIMA waste shredding line

TECHNICAL HIGHLIGHTS



Flexible machine setup

thanks to separate PowerPack

The 280 kW PowerPack can be set up flexibly: directly next to the machine, a few meters away or even in a separate room. An enclosure protects the motors from corrosion, moisture and dirt. If required, soundproof panels can be selected for the enclosure to minimize noise generation.



Mastering abrasive materials

with Hardox wear protection

The cutting shafts are designed to be particularly resistant to abrasive materials and foreign substances such as sand, metals or other contaminants. The cutting knives are made of extremely abrasion-resistant Hardox® 500 steel to protect them against wear and abrasion.



Optimal shredding results

thanks to individual cutting configurations

The cutting shafts can be configured with eight to twelve cutting disks, depending on the required throughput and particle size. The size of the shredded material depends on the number and width of the cutting knives.

Powerfully driven

with hydraulic drive

For the twin-shaft shredders of the M series, WEIMA relies on powerful hydraulics from high quality manufacturers. The hydraulic drive is very responsive – and this at a low connected load. Stopping, starting and reversing is possible even under full load. The speed (15-40 rpm) and torque are infinitely variable without a frequency converter.

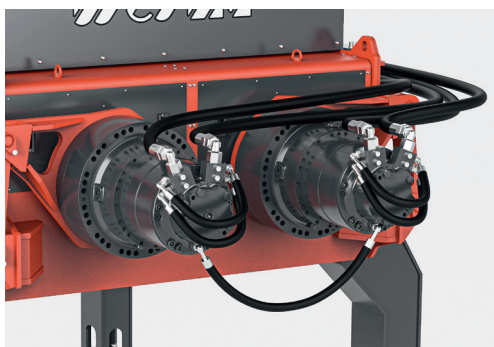

TECHNICAL HIGHLIGHTS

Use in multi-shift operation thanks to hydraulic oil cooling

To compensate for temperature differences in the hydraulic oil, shredders of the M series have an oil cooling system with air cooling. This ensures long operating times without downtime. The voluminous oil tank is equipped with a micro-filter system and thus guarantees the purity of the oil for a particularly long service life.

Shredding particularly large items thanks to large hopper volume

The standard version of the hopper has a capacity of five cubic meters. For feeding particularly voluminous parts or large quantities of material, this can be expanded to eight cubic meters. Filling by gripper is thus conveniently possible.

Convenient maintenance and optimal access to the cutting table thanks to lateral inspection flap

The lateral inspection flap can be opened hydraulically. This facilitates access to the cutting table including cutting shafts for routine maintenance. Foreign matter can also be easily removed manually in this way.



Remote machine operation via remote control or smartphone

The M series can not only be operated via the touch display, but can also be controlled via remote control. Functions such as starting and stopping the shredder, opening and closing the maintenance flap, reversing the cutting shafts and emergency stop can be conveniently monitored. Optionally, the shredder can be controlled via a smartphone app. Function parameters such as throughput, operating hours, maintenance intervals and fill levels can also be accessed there.



TECHNICAL DATA AND MACHINE CONFIGURATION

M8 Technical data M8.28

| | |
|------------------------------------|-------------------|
| Cutting shaft diameter [mm] | 800 |
| Cutting shaft length [mm] | 2 x 2,800 |
| Cutting shaft speed [rpm] | 15 - 40 |
| Drive performance [kW] | 2 x 132 2 x 160 |
| Max. number of cutting hooks [pcs] | 24 |
| Fraction size [mm] | 150 - 500 |
| Discharge dimensions [mm] | 1,900 x 2,800 |
| Loading height [mm] | 3,400 |
| Length [mm] | 5,000 |
| Width [mm] | 2,950 |
| Height [mm] | 3,400 |
| Weight [approx. kg] ¹⁾ | 24,000 |
| Weight PowerPack [approx. kg] | 4,500 |

1) Machine incl. standard hopper and supporting feet

M8 Machine configuration M8.28

● Standard ○ Optional

| | |
|-------------------------------------|---|
| Control cabinet with PLC control | ● |
| Touch display | ○ |
| Hopper with 5 m ³ volume | ● |
| Hopper with 8 m ³ volume | ○ |
| Inspection flap | ○ |
| EES cutting table | ○ |
| Central lubrication system | ○ |
| Remote control | ○ |
| Remote control via app | ○ |
| Support legs | ○ |
| Hydraulic oil preheating | ○ |
| PowerPack with noise protection | ○ |
| Wear kit | ○ |

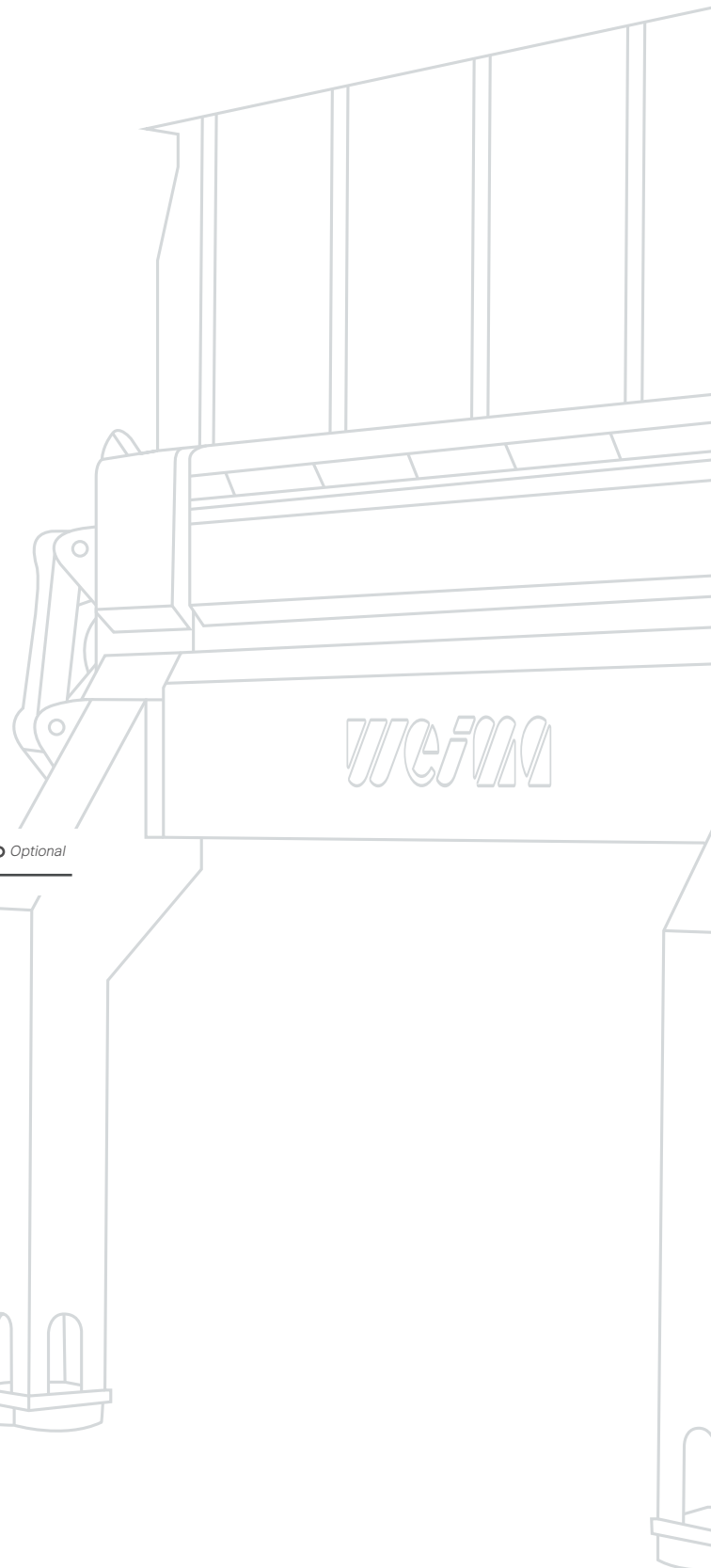



WEIMA Maschinenbau GmbH | weima.com

Bustadt 6-10 | 74360 Ilsfeld (Germany) | Phone: +49 (0)70 62 95 70-0 | Fax: +49 (0)70 62 95 70-92 | info@weima.com